

用途:用于低频功率放大及中速开关。

Purpose:Low frequency power amplifier,medium speed switching applications .

特点:高击穿电压与电流,低饱和压降,有良好的放大特性;与 2SD600K (3DA600K) 互补。

Features:High V_{CE0} , high current, low saturation voltage and good linearity of h_{FE} ; complementary pair with 2SD600K (3DA600K).

极限参数/Absolute Maximum Ratings(Ta=25°C)

参数符号 Symbol	数值 Rating	单位 Unit
V_{CB0}	-120	V
V_{CE0}	-120	V
V_{EB0}	-5.0	V
I_C	-1.0	A
I_{CP}	-2.0	A
P_C	1.0	W
T_j	150	°C
T_{stg}	-55~150	°C

T0-126F 单位: mm

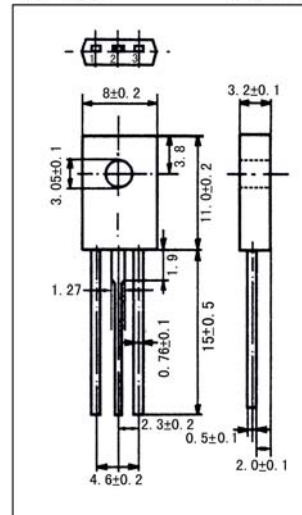

引脚: 1. E 2. C 3. B

电性能参数/Electrical Characteristics(Ta=25°C)

参数符号 Symbol	测试条件 Test Condition		数值 Rating			单位 Unit
			最小值 Min	典型值 Typ	最大值 Max	
V_{CB0}	$I_C = -10 \mu A$	$I_E = 0$	-120			V
V_{CE0}	$I_C = -1.0 mA$	$R_{BE} = \infty$	-120			V
V_{EB0}	$I_E = -10 \mu A$	$I_C = 0$	-5.0			V
I_{CB0}	$V_{CB} = -50V$	$I_E = 0$			-1.0	μA
I_{EB0}	$V_{CE} = -4.0V$	$I_C = 0$			-1.0	μA
$h_{FE(1)}$	$V_{CE} = -5.0V$	$I_C = -50mA$	60		320	
$h_{FE(2)}$	$V_{CE} = -5.0V$	$I_C = -500mA$	20			
$V_{CE(sat)}$	$I_C = -500mA$	$I_B = -50mA$		-0.15	-0.4	V
$V_{BE(sat)}$	$I_C = -500mA$	$I_B = -50mA$		-0.85	-1.2	V
f_T	$V_{CE} = -10V$	$I_C = -50mA$		110		MHz
C_{ob}	$V_{CB} = -10V$	$f = 1.0MHz$		30		pF

$h_{FE(1)}$ 分档/ $h_{FE(1)}$ Classifications: D:60~120 E:100~200 F:160~320



2SB631K (3CA631K)

